

# PH10MQ motorised probe head

## Increase throughput and CMM working volume with a PH10MQ

The PH10MQ is a quill version of the PH10M motorised probe head. It is designed to increase throughput by giving DCC machines the capability of probe re-orientation while maximising the CMM working volume. The probe is able to inspect features at different angles without the need for frequent, time-consuming, stylus cluster changes.

PH10MQ is compatible with a range of both contact and non-contact scanning sensors and touch trigger probes, allowing the size, position and form of critical features to be determined.

Renishaw's autochange systems, used in conjunction with PH10MQ, provide fast repeatable probe and extension bar exchange, without the need for re-qualification of the stylus tip, helping to maximise productivity.

The PH10MQ is an increasingly popular product that provides a cost effective automated probing solution for a wide range of applications.

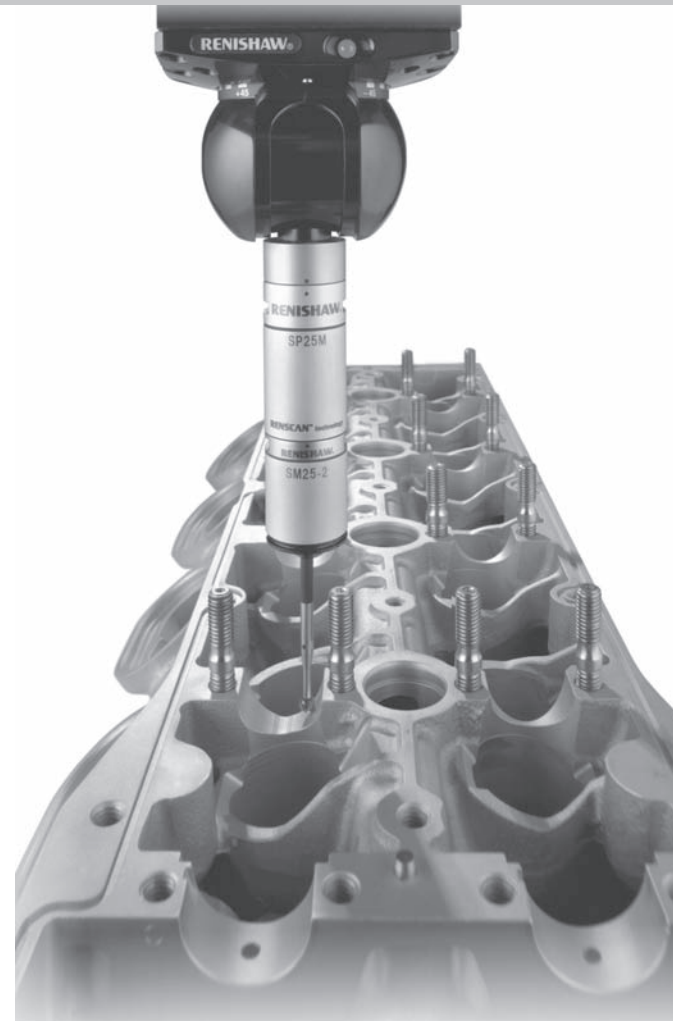

### Key benefits

#### Increased throughput

The ability of the PH10MQ to index automatically reduces the number of stylus changes required, thereby increasing the throughput of your CMM. Indexing is faster than stylus changing.

#### Improved accuracy

The PH10MQ can achieve 0.5 µm repeatability at 62 mm radius, providing accurate positioning even when using long extensions.

#### Increased reach and flexibility

Extension bars up to 300 mm long together with the full range of Renishaw autojoint and M8 probes can be used with PH10MQ.

### Innovations

#### Repeatable kinematic location

The PH10MQ uses six point kinematic location for each of its 720 positions making its locking mechanism extremely repeatable.

#### The Renishaw autojoint

This patented feature allows repeatable automatic probe exchange without the need for stylus re-qualification.

#### UCC compatibility

The PH10MQ can be used in conjunction with Renishaw's UCC controller family providing a comprehensive solution.

## Specification

<b>Weight</b>	730 g (25.7 oz)
<b>CMM mounting</b>	Direct to quill
<b>Probe mounting</b>	Renishaw autojoint (multiwired) M8 threaded probes can be used with PH10MQ via a PAA probe adaptor
<b>Suitable controller</b>	PHC10-2 (RS232 and IEEE versions available) or, PHC10/50 UCC daughter card
<b>Repeatability of position</b>	0.5 µm (0.00002 in) specified at a distance of 62 mm (2.44 in)
<b>Cycle time</b>	
<b>75° move:</b>	2.5 seconds
<b>90° move:</b>	3.5 seconds
<b>Total angular movement</b>	
<b>A axis</b>	0° to 105° in 7.5 steps
<b>B axis</b>	0° to ±180° in 7.5 steps
<b>Total number of positions</b>	720
<b>Maximum drive output torque</b>	0.45 Nm
<b>Maximum extension bar</b>	300 mm (11.8 in) using PAA3 probe adaptor
<b>Temperature range</b>	
<b>Operating:</b>	10 °C to 40 °C (50 °F to 104 °F)
<b>Storage:</b>	-10 °C to 70 °C (14 °F to 158 °F)
<b>Hand control unit</b>	HCU1
<b>Autochange systems</b>	ACR1/ACR3

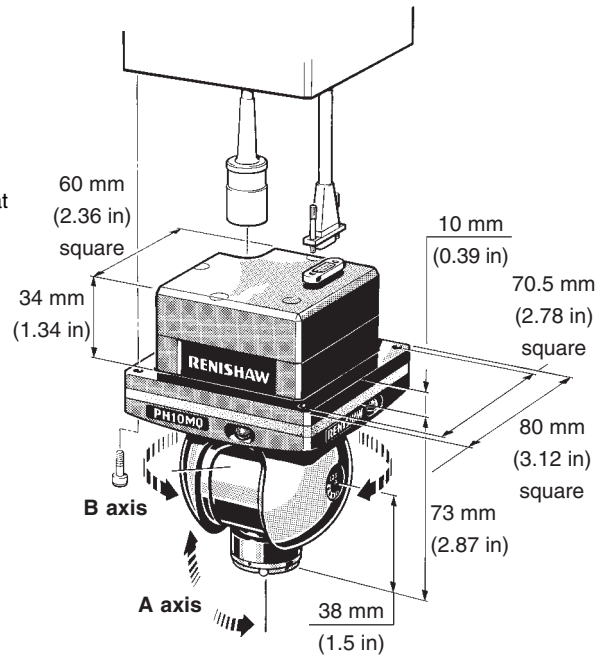

## Additional information

Other variants of the PH10MQ are also available. These are PH10M and PH10T, both shank mounted products. For further details on these, and related products refer to [www.renishaw.com/PH10](http://www.renishaw.com/PH10).

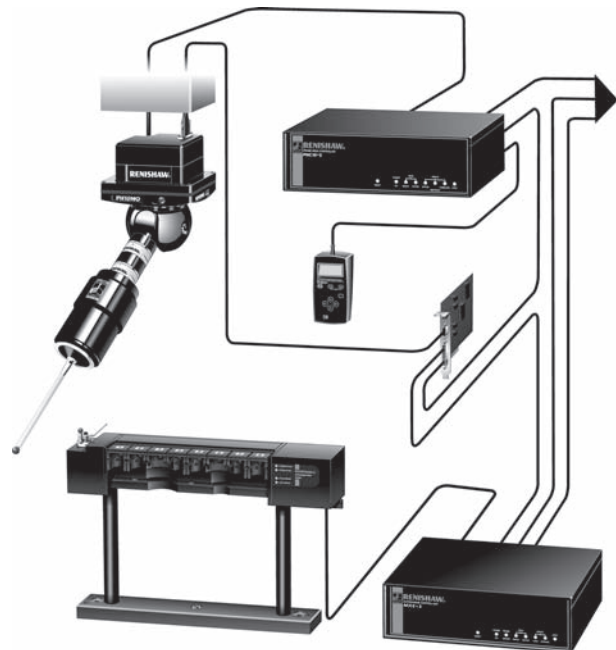

For worldwide contact details, please visit our main website at [www.renishaw.com/contact](http://www.renishaw.com/contact)